



Absolute performance

STUDIO

Design is in the detail

Since 1972 Monitor Audio has been at the leading edge of loudspeaker design and technology, renowned for exemplary speaker cabinet construction and finishes. The quest to design an elegant and powerful loudspeaker that will grace any setting has led to the creation of Studio. With a sleek silhouette, unique design touches, and featuring technologies from Monitor Audio's flagship Platinum II series, Studio sets a fresh audio benchmark.

Studio is a premium loudspeaker offering absolute performance from within the clean lines of its compact cabinet. The speaker's architecture has been configured to deliver the most faithful sound reproduction possible.

The grille-less design ensures the speaker's voice is clear and true, and lets the drivers become an eye-catching focal point. The two metallic-silver RDT II speaker cones deliver an optimum high-end performance that will delight music lovers. The honeycomb tweeter cover adds a contemporary edge to the speaker's form, and the bespoke aluminium badge at the cabinet's base gives a stylish design touch.

Handcrafted, and available in a sleek satin black, white or grey finish, Studio is a stunning addition to any room.



Audio blueprint



STUDIO

TECHNOLOGY

The Studio speakers have been carefully designed to deliver the pure pleasure of a detailed and accurate audio performance. Their sound is clear and natural, with a deep bass and plenty of mid-range detail.

Whichever music source is selected (Vinyl, CD, streaming or radio), the Studio's performance is certain to delight the listener.

DRIVER DESIGN



RDT II Driver (Rigid Diaphragm Technology 2nd Generation)

The drivers are designed to be incredibly low in distortion and use the same magnetic design principles and material choice as Monitor Audio's class-leading flagship speakers.

RDT II is a composite 'sandwich' structure made from ultra-thin low mass skins, bonded to a honeycomb Nomex® core material. Very light and very strong, responds with great speed without bending. RDT II uses C-CAM for the front skin, while the rear skin is made from a woven carbon fibre material. This structure reduces distortion by over 8 dB above 300 Hz.



MPD (Micro Pleated Diaphragm) High Frequency Transducer

An MPD high frequency transducer has been designed to provide incredible articulation due to its low mass diaphragm.

MPD transducer uses a proprietary low-mass pleated diaphragm with a surface area eight times larger than that of a traditional dome tweeter. It works like a super-fast accordion by rapidly squeezing the pleats to produce a smooth, wide and naturally fast response up to 100 kHz. As a result, the sound is more lifelike, releasing the high harmonic spectrum of every note without the distortion that blurs definition.

Diaphragm in normal state



Diaphragm in use

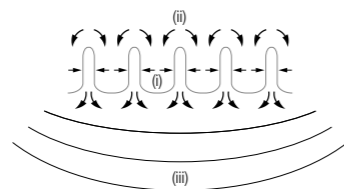

- (i). Shows the force/motion of the diaphragm
- (ii). Shows the direction of the airflow in the mid field
- (iii). Shows the acoustic wave-fronts resulting from the airflow

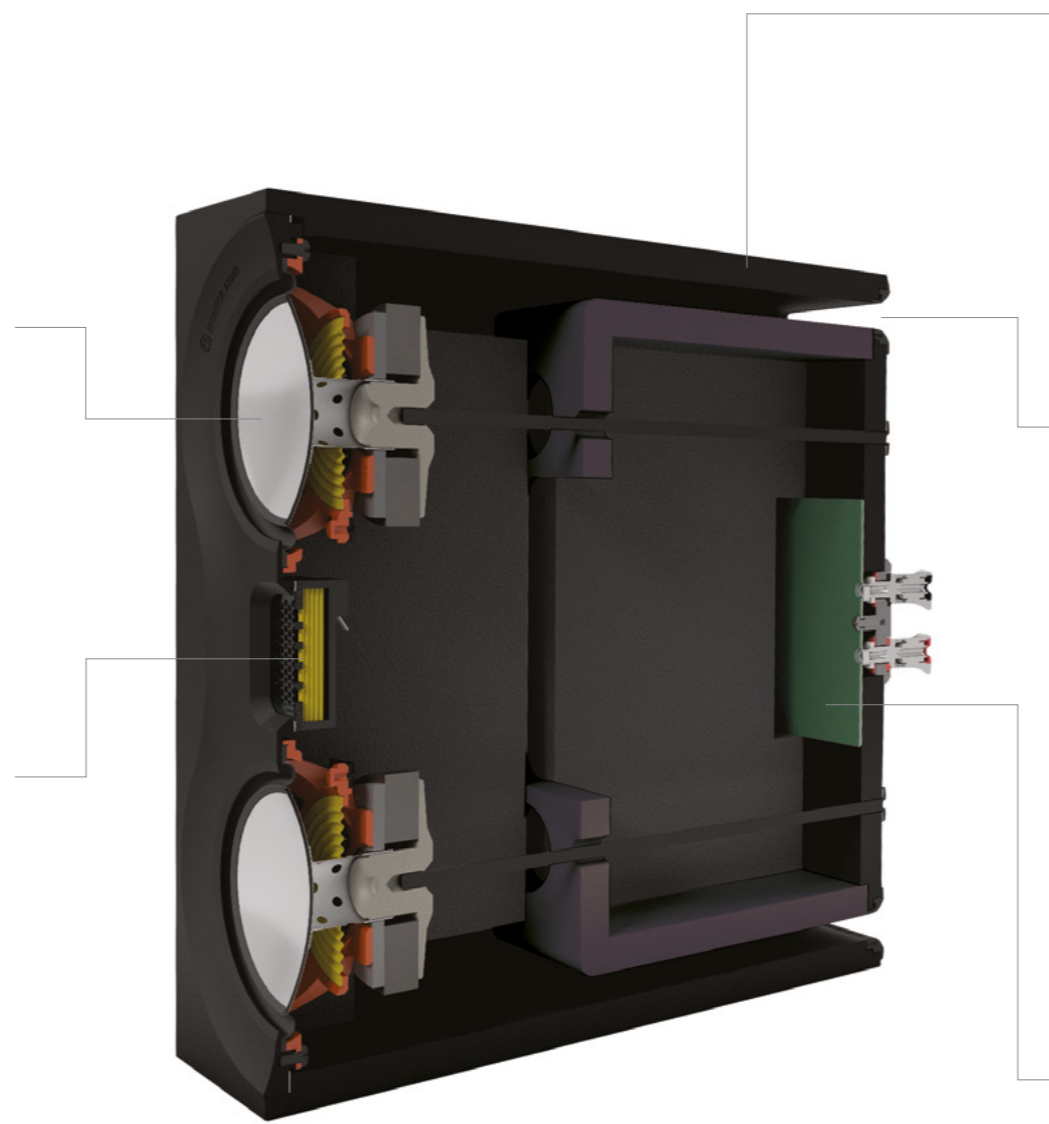

MECHANICAL AND VISUAL DESIGN

Cabinet

The cabinets are handcrafted using rigid MDF and finished in a satin black, white or grey finish. The design is completed with a unique aluminium badge to the cabinet side.

The drivers are mounted and clamped by a rigid die-cast aluminium sub-baffle to provide rigidity. The mechanical structure is enhanced further using bolt through driver technology to provide the ultimate cabinet bracing.



Studio Hive II Slot Port

The Studio's super-slim cabinet is tuned using two rear-mounted Monitor Audio HiVe II ports at the top and bottom of the cabinet. The dual ports ensure the pressure inside the cabinet is symmetrically balanced. HiVe II port uses a straight rifled design to accelerate air flow to reduce turbulence and air noise. This technology has the ability to move air in and out much quicker than a conventional port, the result is fast powerful bass coupled with superior transient response.

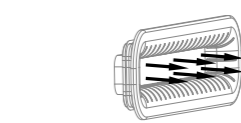
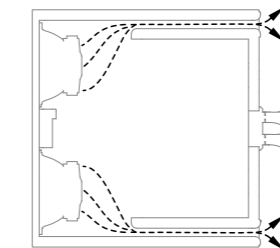

Due to the larger surface area of the Studio HiVe II slot port, there is a more even air velocity distribution across the whole port compared to a conventional HiVe II port



Crossover and Rhodium Plated Terminals

Studio's crossover, the electrical circuit used to split the signal into treble and bass, uses high-grade polypropylene film capacitors, air-core and laminated steel-core inductors that have been selected to preserve the best possible signal integrity. The purist electrical chain is complemented by a pair of precisely machined terminals developed for the flagship Platinum II series. These provide the lowest contact resistance and long-term consistency, precision milled from solid copper with rhodium plated conductor parts. Rhodium has been selected for its excellent electrical conductivity and resistance to oxidation. Terminals are designed to accept a spade, 4 mm banana plug or bare wire, up to 4 mm in diameter (7AWG).



True sound



KEY FEATURES

- Delivers detailed and accurate audio performance
- Ultra-slim, compact cabinet profile
- 2 x 4" RDT II drivers with C-CAM technology and rigid cast polymer chassis
- MPD (Micro Pleated Diaphragm) high frequency transducer
- HiVe II (High Velocity) reflex slot configuration ports
- Precision machined, rhodium plated speaker terminals
- Rigid die-cast aluminium sub-baffle to mount and clamp drivers securely
- Bolt through driver technology: clearer sound and cleaner aesthetics
- Contemporary satin finish in black, white or grey
- Optional bespoke floor stand (STAND) in black or white finishes

SPECIFICATIONS

Model	Studio
System format	2-way
Frequency response (-6dB)	48 Hz – 60 kHz
Sensitivity (1W@1M)	86 dB
Nominal impedance	4 ohms
Minimum impedance	2.9 ohms @ 3.5 kHz
Maximum SPL	110 dBA (Pair)
Power handling (RMS) Watts	100 W
Recommended amplifier requirements (RMS)	40 – 100 W
Bass alignment	Dual slot Bass reflex – HiVe II port system
Crossover frequency	2.7 kHz
Drive unit complement	2 x 4" RDT II drivers 1 x MPD high frequency transducer
Cabinet dimensions (H x W x D) (including terminals)	340 mm x 156.2 mm x 360.9 mm 13 ^{3/8} x 6 ^{1/8} x 14 ^{3/16} "

FINISHES

Satin white, grey or black

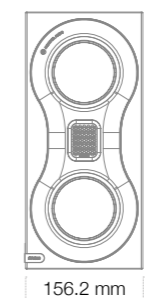

STAND

Sound Stability

STAND has been created to improve both the visual appearance and audio performance of Monitor Audio's premium Studio speakers. Delivering perfect stability and audio reproduction, the stands offer a striking improvement to any speaker set-up.

To ensure optimum rigidity, and a perfect listening experience, bespoke metals have been used for each section of STAND: the top plate is laser-cut steel, the pole is extruded aluminium and the base is die-cast aluminium. The four adjustable feet have chrome plated spikes for carpeted floors and domed rubber feet for hard floors to ensure that the stands are stable in all situations.

STAND can also be used with other bookshelf speakers. Whichever speakers are used, STAND will ensure they reach their potential by delivering the best in terms of sonic punch, detail and rhythm.

With a choice of black or white finish, STAND complements any speaker in any room.

KEY FEATURES

- Bespoke top plate with bolt fixing points specific for Studio speakers
- Extruded aluminium pole, fillable for mass loading
- Die-cast aluminium base
- Chrome plated spikes for carpeted floors
- Rubber feet provided for use on hard floors

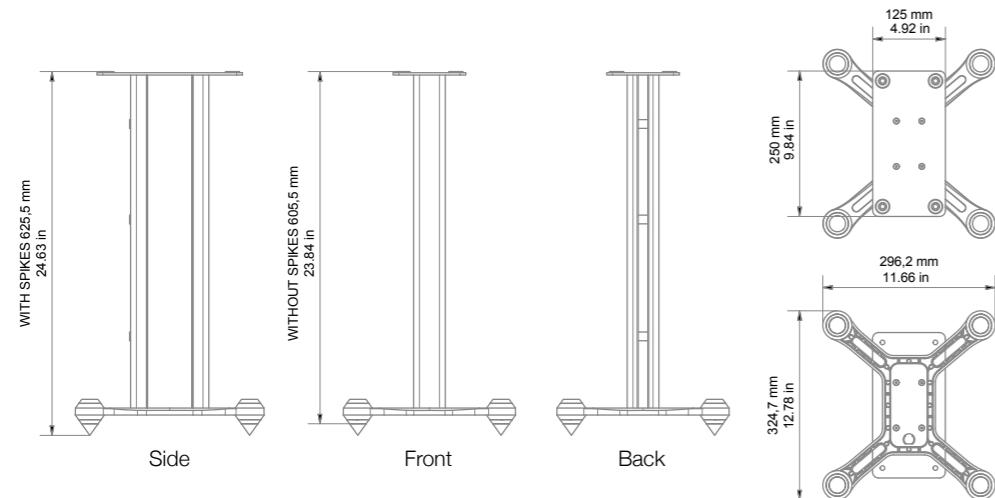

SPECIFICATIONS

Model	STAND
External Dimensions (H x W x D)	605.5 mm x 296.2 mm x 324.7 mm 23 ¹³ / ₁₆ " x 11 ¹ / ₁₆ " x 12 ¹³ / ₁₆ "
External Dimensions (H x W x D) (including spikes)	625.5 mm x 296.2 mm x 324.7 mm 24 ⁵ / ₈ " x 11 ¹ / ₁₆ " x 12 ¹³ / ₁₆ "

FINISHES

Black or white





E&OE All colours approximate.

For more information email info@monitoraudio.com
Additional technical details on the Studio speakers
and STAND are available at monitoraudio.com

Monitor Audio Ltd
24 Brook Road, Rayleigh,
Essex, SS6 7XJ, England
T. + 44 (0)1268 740580
F. + 44 (0)1268 740589
E. info@monitoraudio.com
monitoraudio.com

