

9				10		
ECO NR.	DATE	CHG.	ZONE	DESCRIPTION OF CHANGE	REL.	CHK.
--	--	--	--	--	--	--
--	--	--	--	--	--	--
--	--	--	--	--	--	--
--	--	--	--	--	--	--
--	--	--	--	--	--	--
--	--	--	--	--	--	--
--	--	--	--	--	--	--
--	--	--	--	--	--	--
--	--	--	--	--	--	--

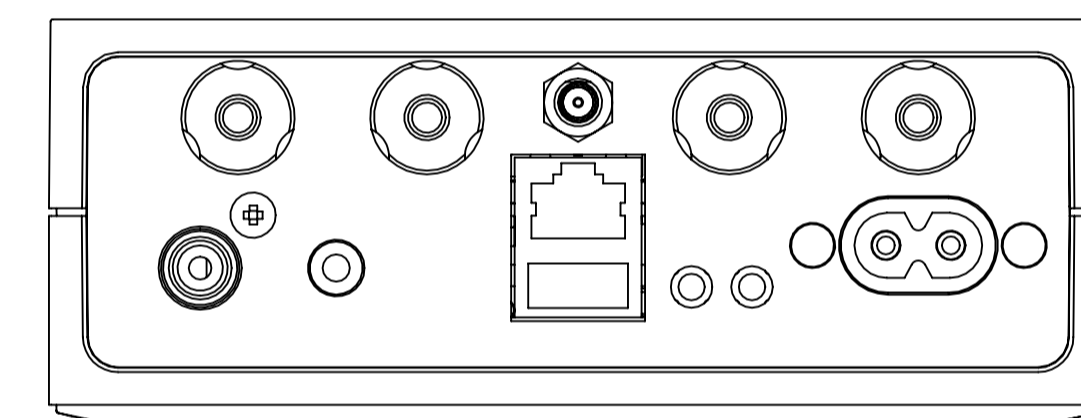

REAR VIEW

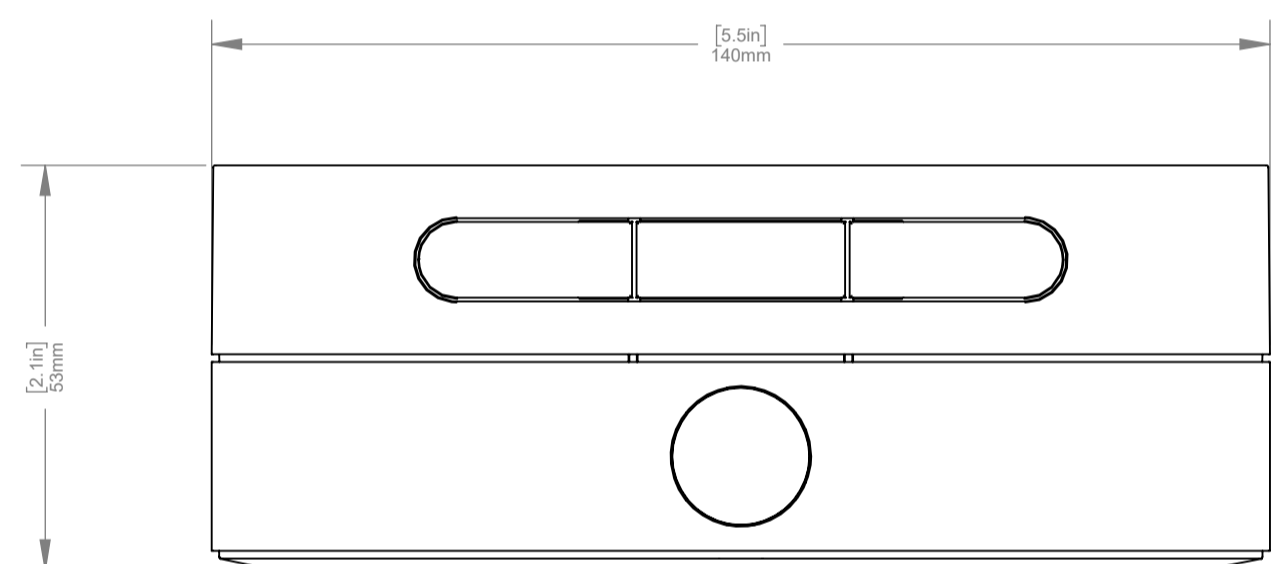
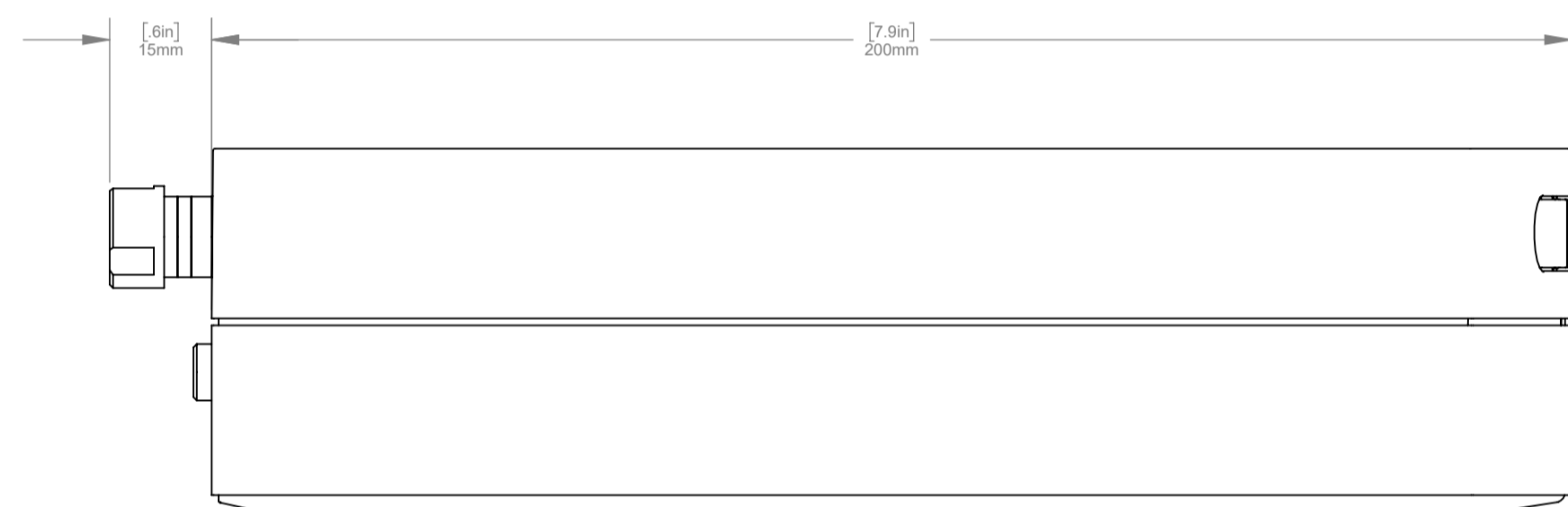
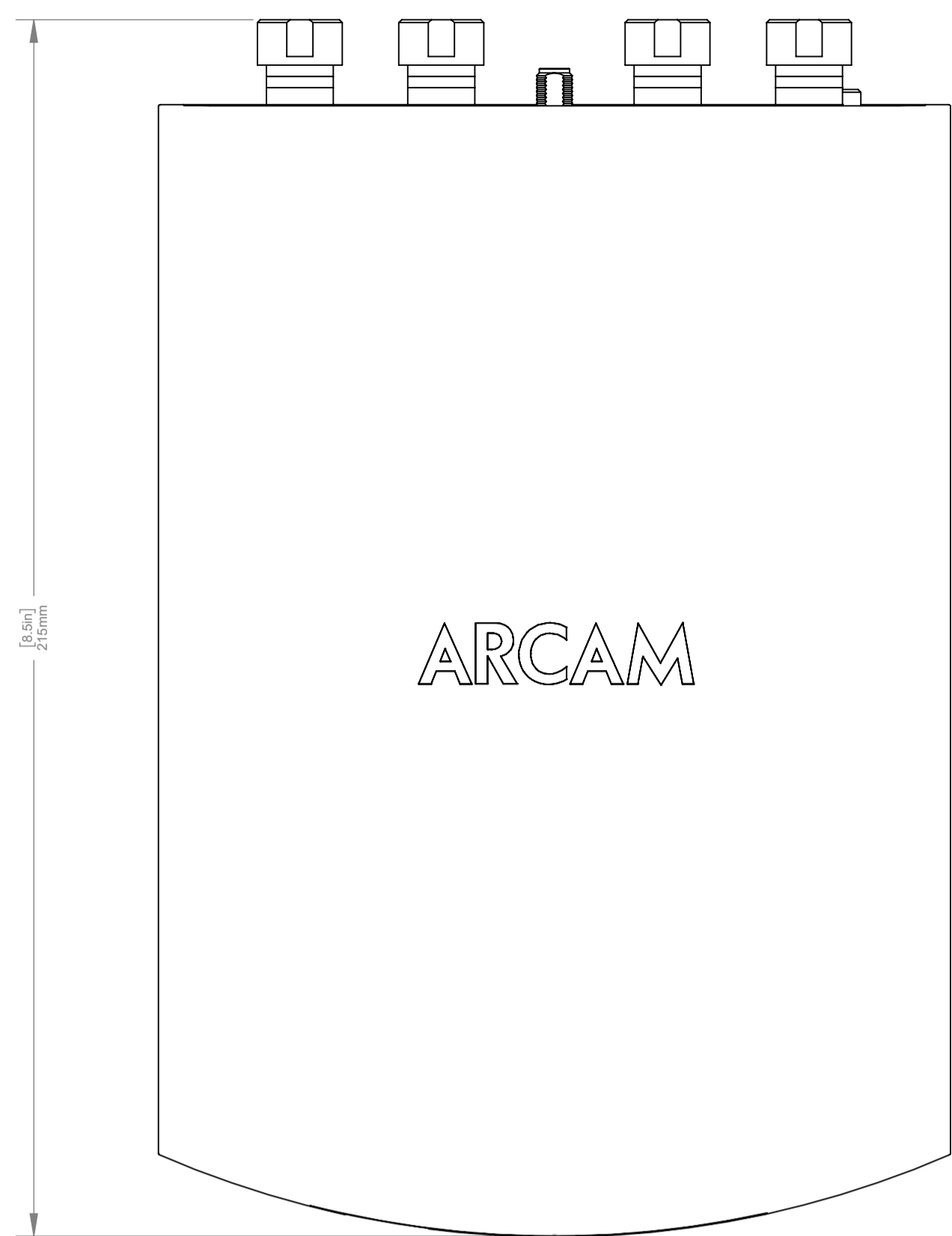
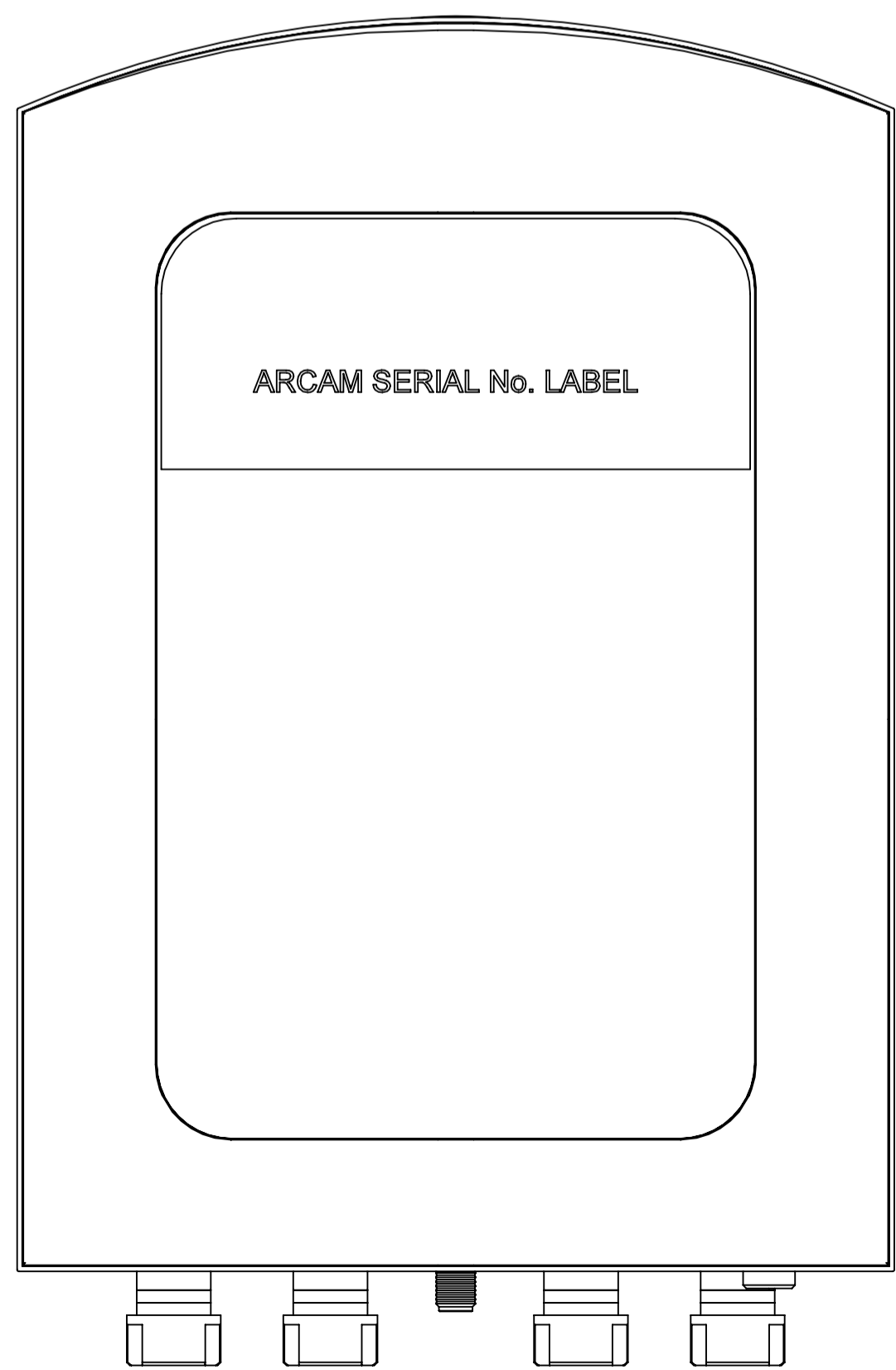

**NOTE:**  
ALLOW ADEQUATE CLEARANCE  
AROUND THE PRODUCT FOR  
VENTILATION & CONNECTION

<b>ARCAM</b> <small>A &amp; R CAMBRIDGE LTD</small> <small>LINEAR TOLERANCE +0.2MM UNLESS OTHERWISE STATED</small> <small>ANGULAR TOLERANCE +1° UNLESS OTHERWISE STATED</small>	<small>DRAWN BY:</small> MCM <small>DATE:</small> 9-10-2019
	<small>CHECKED BY:</small> -- <small>ORIGINAL SCALE:</small> 1:1
<small>MATERIAL:</small>	<small>SHT 1 OF 1</small>
<small>PART NUMBER AND DRAWING NUMBER</small> <b>SOLO UNO-2</b>	
<small>DRAWING TITLE</small> <b>UNO-2 ASSEMBLY</b>	<b>A1</b>

